

## An Update on Bowstring Truss Issues

Paul C. Gilham, P.E., S.E., Chief Engineer, Western Wood Structures, Inc.  
Brentley A. Matthias, P.E. Senior Project Engineer, Western Wood Structure, Inc.

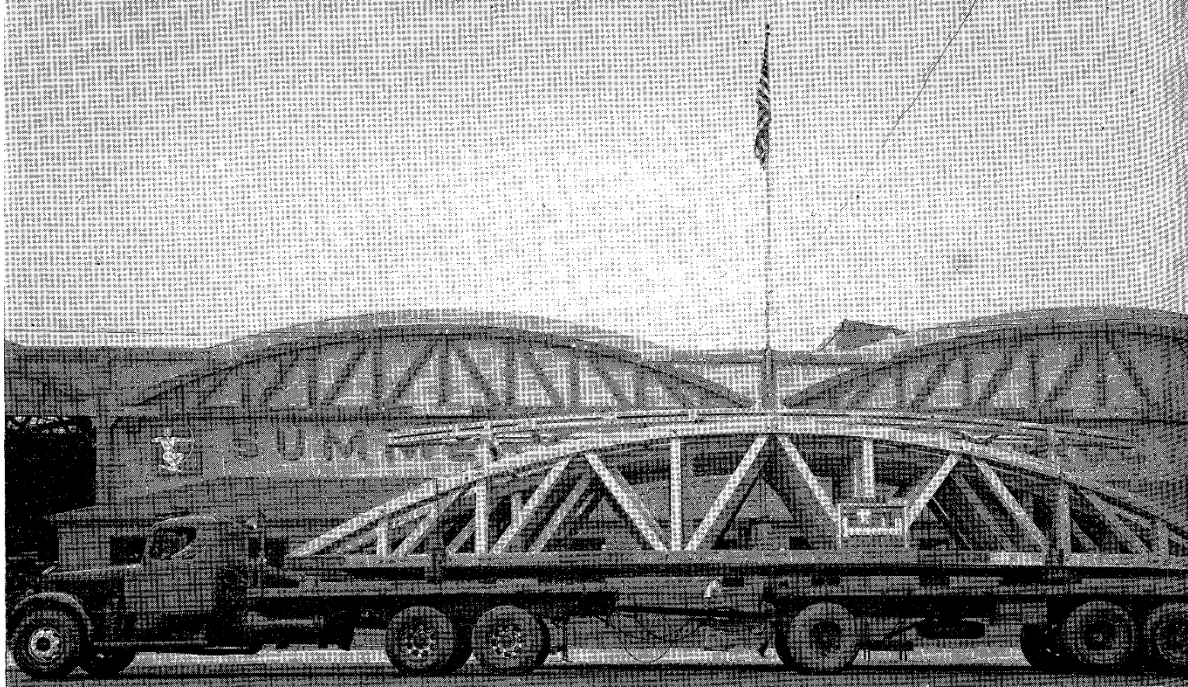

Photo #1. "Summerbell Trusses" leaving the plant toward a new structure

### Introduction

In 2009, engineers from Western Wood Structures (WWS) published a white paper entitled, "Bowstring Trusses "Fail" to Meet Current Code Requirements." [1] That paper described two common bowstring truss types and discussed three significant issues related to the design of bowstring trusses. Bowstring trusses are characterized by a circular curved top chord and a straight bottom chord. The top chord is usually made with a radius of curvature equal to the span of the truss. This radius provides for the most economical design and results in a 30-degree spring angle at the truss heel.

This paper adds to the knowledge base of the previous one. The history of these trusses, including changes to snow loading requirements, changes to the allowable timber stresses, and changes to timber grading rules are examined to provide a more thorough understanding of truss performance.

The truss types described in the previous article were ARCH-TECO Trusses (TECO) and Tim Trusses. Both TECO Trusses and Tim Trusses were designed and manufactured by Timber Structures, Inc. The TECO Trusses were prevalent in construction from the mid-1940s to the mid-1950s. The basic configuration of the TECO truss is included in reference [1]. Several common failure modes observed in TECO are included in this paper. Tim Trusses had spans up to 160 feet and were used in construction beginning in the mid-1950s. Since the publishing of

the white paper in 2009, WWS has encountered two other common types of bowstring trusses, the Summerbell Truss and the Belfast/Mckeown Lattice Truss.

### Summerbell Truss

Summerbell bowstring trusses use a laminated curved top chord. The top chord utilizes a series of 2 in. or 3 in. thick boards to form a curved top chord. The laminations were glued together using casein adhesive. The curvature of the top chord was established using a curved rack and nails were used to fit the laminations to the curve until the adhesive set. Often, one of the laminations is wider than the remainder of the laminations. This wide top chord lamination is often used as a ledger for the roof joists to bear on. The Timber Engineering Company, the supplier of split ring and shear plate connectors provided a design pamphlet that included fabrication drawings and specifications for the trusses. [2] The curved top chord laminations are spiked together with two rows of spikes spaced at 12” on center and located approximated 1” from the edge of the members. The size of the spike was determined by the number of laminations included in the top chord. The laminations are further reinforced with a ½” diameter bolt located at each panel point. These trusses were often referred to as “Summerbell” trusses after a manufacturer who built many of this type of truss. These trusses had spans up to 120 feet and were prevalent from the late 1930s to the late 1940s.

In trusses inspected by WWS, there is no evidence that the adhesive remains. A steel feeler gauge can be inserted completely through the chords between the laminations, much like a dry glue joint. A research note prepared by the Forest Products Laboratory indicated that to achieve a bond stronger than the wood itself, the laminations should be clamped under a pressure of 150 to 200 pounds per square inch. [3] The open face bonds indicate that the nailing did not provide enough pressure for the adhesive to form a permanent face bond. The nailing and bolting of the laminations alone are not adequate to achieve a composite section. Therefore, the section properties of the top chord are simply the sum of the cross sections for the individual laminations. See photo #2.

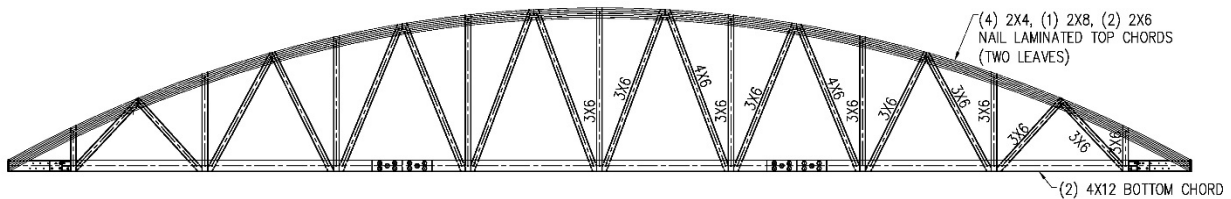

Figure 1. Example of a “Summerbell” Truss.

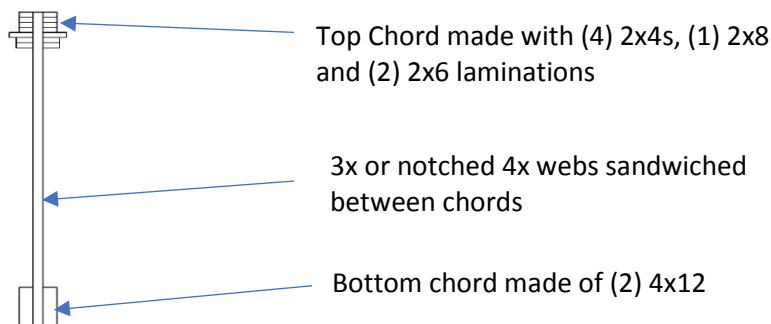

Figure 2. Cross Section of “Summerbell” Truss shown in figure 1.

For example, the top chord in photo #2 uses (7)  $1\frac{5}{8}$ " x  $3\frac{5}{8}$ " laminations. With effective adhesive attaching all of these laminations, the moment of inertia (I) is  $444.61 \text{ in}^4$  and the section modulus (S) is  $78.17 \text{ in}^3$ . Without adhesive between the laminations, the moment of inertia is  $9.07 \text{ in}^4$  and the section modulus is  $11.17 \text{ in}^3$ . The bending strength in the section with no adhesive is seven times less than the section with an effective bond between laminations.



Photo #2. Top chord showing effects of adhesive deterioration

### **Belfast/McKeown Lattice Truss**

Belfast/McKeown Lattice type of bowstring truss has a lattice pattern for the webs. An article in Structure Magazine by Don Eschenacy, P.E. FSEI, SECB refers to these trusses as Belfast bowstring trusses [4]. Other documents refer to these trusses as McKeown Lattice Trusses. [5] See Figure 3.

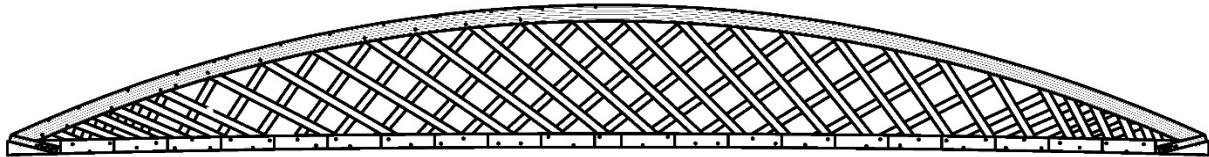

Figure 3. Example of a Belfast or McKeown Lattice Truss

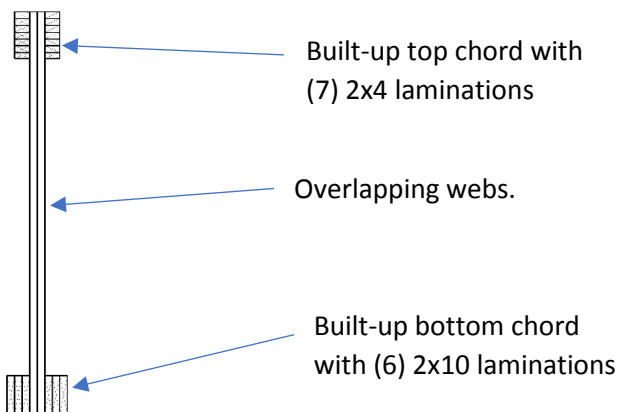

Figure 4. Lattice Truss Section of truss shown in figure 3.

Top chords are made with laminated 2x members, oriented horizontally. The curve is established by bolting the bottom lamination to the webs. The remaining laminations are nailed together with a series of 40d, 20d and 16d nails. The chords are attached to the lattice webs with (2) rows of ½” diameter machine bolts in each lattice member. The bottom chords consist of two runs of three 2x members oriented vertically on each side of the lattice webs. These members have staggered splices such that two members in each run are effective at any section. The webs are single 2x members, nailed together with (4) 16d nails at each intersection.

WWS is in possession of a design drawing of one of these trusses prepared by McKeown Bros. Co. These drawings are dated April 1924 which would make these trusses the oldest of the four common bowstring truss types.

**“My trusses are 75 years old. Why don’t they meet the code requirements or why are they breaking now?”**

These are the most common questions WWS encounters when speaking with owners, general contractors, engineers, architects and insurance adjusters. The trusses do not meet the current code requirements due to the following issues.

1. Changes in allowable timber design stresses
2. Improvement in computer analysis methods
3. Changes in building code roof loading requirements

In addition, there are many issues that influence the ability of these trusses to support the applied loads. These include:

4. Partial support of the top chord at the bearings
5. Row tear-out and group tear-out of bolted connections
6. Decay of members
7. Overframed roofs
8. Added loads
9. Damage from building use (forklift collisions, etc.)
10. Duration of load behavior of timber members.

**Changes in allowable timber design stresses**

The first issue is related to the reduction of the allowable stresses for tension for sawn lumber. At the time that these trusses were most popular, the testing apparatus was not able to load a full size tension specimen to failure. Therefore, the allowable tension stress was set equal to the allowable bending stress. (Assuming that the tensile stress due to bending was equal to the axial tension stress.) Table 25-A of the 1967 Uniform Building Code combines Extreme Fiber in Bending and Tension Parallel to Grain in the same column. [6] In the late 1960s improved testing equipment was developed that could load the full-size specimens to failure in axial tension. This advancement in the testing equipment and subsequent testing led to a reduction in the allowable tensile stress for sawn lumber. [7] For Douglas fir #1, prior to 1967 that value was 1450 psi. Today, the allowable tension stress is equal to 675 psi multiplied by the size factor,  $C_F$ . For a 3x10 member, that allowable tension stress is  $675 * 1.1 = 742.5$  psi. [8]

For trusses with glued-laminated chords, a similar reduction in allowable tension values is required since the published allowable stresses were based on the assumed strength of sawn members. AITC Technical Note #26 recommends using 5/8 of the published tension stress for laminated timbers manufactured prior to 1970. [7].

Evaluating the capacity of a bowstring truss includes determining the grade of the lumber used in the truss and then assigning appropriate allowable stress values. A common misconception is that the lumber used to build these trusses is “old growth” and is better than the lumber available today. Design assumptions made with this misconception lead designers to use Select Structural design values for truss elements. However, when today’s lumber is compared grade for grade to the lumber used to fabricate these trusses, the members have equivalent strength. While higher grade lumber was more prevalent when these trusses were common, higher grade members were commonly mixed in with an order for lumber. However, one cannot guarantee that the critical members have higher grades. It is appropriate to use the specified grade of lumber in all analyses and repair designs.

Finding a grade stamp on lumber in these buildings is very rare. Therefore, an alternate method of determining the grade is required. It is possible to have the members re-graded by a certified lumber grader. However, re-grading the lumber is subject to limitations of access. Finishes such as paint can make measuring knot sizes and slope of grain difficult.

Alternatively, the grades used at the time of fabrication can be determined by original or historical drawings and then correlated with current grades of lumber. The allowable knot sizes and slope of grain requirements required for the original grade can be matched to a current lumber grade and current allowable stresses associated with the comparable grade.

The drawings available for “Summerbell” trusses specify an extreme fiber bending stress between 1200 psi. and 1450 psi. The Standard Grading and Dressing Rules #14 [9] has the same knot sizes and slope of grain requirements for a 1450f grade member as the current Standard #17 Grading Rules for West Coast Lumber [10] for a Douglas fir #1 member. It can be concluded, that the lumber used to build these trusses, and the current allowable stresses assigned to the truss material is equivalent to current Douglas fir #1.

The drawings available for TECO type trusses specify Paragraph 204 of the WCLA Rules #14 which correlates to lumber with an allowable bending stress of 1450 psi. These grades correlate to current Douglas fir #1 using the grading requirements of WCLIB Grading Rules #17.

The Standard Grading and Dressing Rules #14 contained a provision that allowed relaxation of the knot size and slope of grain requirements in the outer third of the member length. The majority of structural joists and planks are used as bending members with the bending moments greatest in the middle portion of the span. The relaxation of the knot size and slope of grain allowed for lower quality wood in the portion of the member with lower bending stresses. With truss chords, however, the axial force is the primary force and the bending moment is the secondary force. The axial force in the bottom chord of a bowstring truss is fairly constant along the length of the chord and the maximum moment is often at the first truss panel point which is located outside of the middle third of the member. Therefore, the weaker portion of the member

is subjected to the maximum forces. The relaxed grading rules, for a Douglas fir #1 member correspond to the grading rules of a current Douglas fir #2 member. Therefore, in the outer third of any tension member, current Douglas fir #2 values should be assumed.

Determining the grades of lumber used in Tim Trusses requires reverse engineering. The drawings for these trusses were templates that left the grade of the material blank, to be filled in to meet the job specific loading requirements. The allowable stresses used in the original design can be obtained by solving for the required tensile stress of the member, based on the loading requirements at the time of construction. Once the tension stress is determined, the historical glued laminated timber grade can be chosen and the allowable stresses at the time of construction can be determined. Then the appropriate current allowable tensile stress can be found by multiplying original allowable tension stress value by  $5/8$ . At that point, a current laminating grade with equivalent allowable tension stress can be chosen and the associated current allowable stresses for compression and bending can be used to evaluate the truss.

For example, if the required tension stress in the original design is found to be 2,000 psi., the appropriate allowable stress for the member is  $2,000 * 5/8 = 1,250$  psi. The current Combination 2 laminating grade has an allowable tension stress of 1,250 psi. The allowable bending stress and compressive stresses for Combination 2 laminating grade can be used in the design check for the members.

### **Improvement of Analysis Methods**

The original technique used to determine the member forces for these trusses was a graphical method that used classical truss analysis methods. With the classical method, the members are pinned at each joint and the loads were applied at the joints. This method was only able to determine the axial forces in the members. It did not yield any bending moments or shear forces. Some designers applied a bending moment to the top chord based on the three-beam equation and added an additional bending moment to the top chord by multiplying the axial force by the eccentricity caused by the curvature of the roof. [11] These analysis methods did not adequately account for member continuity over a joint, the eccentric placement of web to chord connections or the secondary moments caused by deformations. To capture all the forces applied to the truss members these trusses should be modeled using frame analysis software. By computer modeling the truss, including the effects of member continuity at the joints, the eccentricity of the web to chord joints, the curvature of the top chord and non-prismatic sections at the top chord, more exact member forces can be determined. The analysis results often yield large moments in the top and bottom chords at the first vertical web. These members can then be checked for combined bending and axial stresses using the provisions of the National Design Specification for Wood Construction [12] (NDS) The addition of the bending stresses at the joint often causes a substantially overstressed condition in the top chord and bottom chord at the first joint, which is often the location of the first failure in the truss. See Figure 5



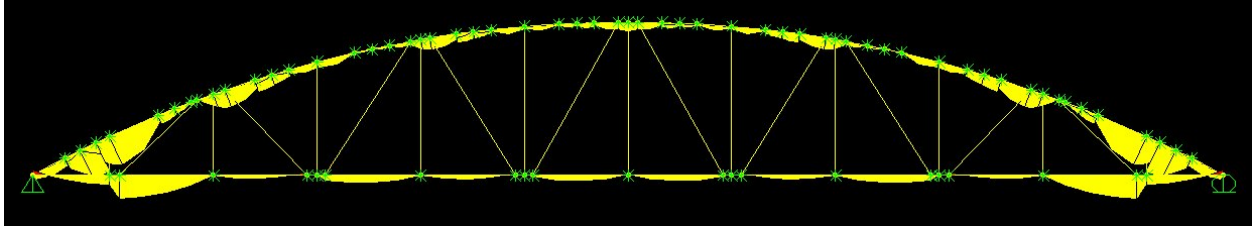

Figure 5. Moment diagram of truss modeled with actual member continuity and eccentric web connections.

### Changes to Roof Loading Requirements.

The loads used when these trusses were originally designed were significantly different than the loads required today by the building codes. From the first Uniform Building Code (UBC) in 1927 [13] until the 1940 UBC consideration of snow loads was not mentioned. In the 1940 UBC, a single sentence covered the snow load criteria, “Where snow loads occur, roofs shall be designed for the increase in loading.” [14] The roof live load used from 1927 to 1935 was 30 psf. for roofs with a slope less than 4:12 and 25 psf. for roofs with slopes greater than 4:12 and less than 12:12. In the 1940 UBC the roof live load was reduced to 20 psf. and in the 1949 UBC the roof live load was permitted to be reduced based on tributary area and roof slope.

The 1949 UBC contained the following clause for unbalanced loading, “Trusses and arches shall be designed to resist the stresses caused by unit live loads on one-half of the span if such loading results in reverse stresses, or stresses greater in any portion than the stresses produced by the required unit live load upon the entire span.” The snow load requirements were also modified as follows, “Snow loads, full or unbalanced, or wind loads shall be considered in place of loads in Table No. 23-B, where such loading will result in larger members or connections.” [15]

Before the unbalanced load requirement, these trusses were designed such that most of the webs would be in tension. Webs stressed in compression were usually wider to reduce the  $L/d$  ratio. When an unbalanced load is applied, the forces in many of the webs change from tension to compression. The strength of the longer web members is governed by the  $L/d$  ratio. Many of these webs have an  $L/d$  ratio greater than 50 which is not allowed by the NDS.

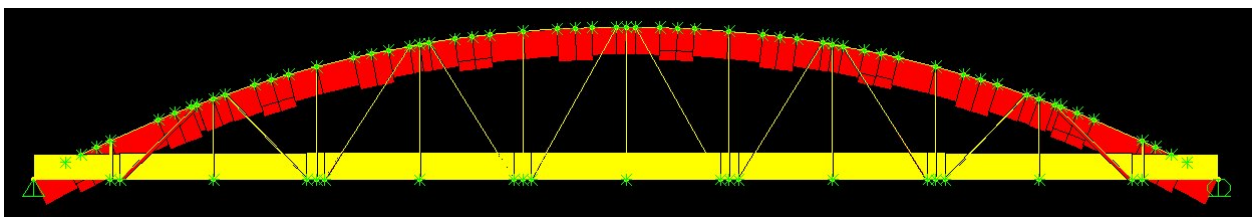

Figure 6. Axial loads under balanced dead load plus snow load. All webs except the first diagonal web are stressed in tension.

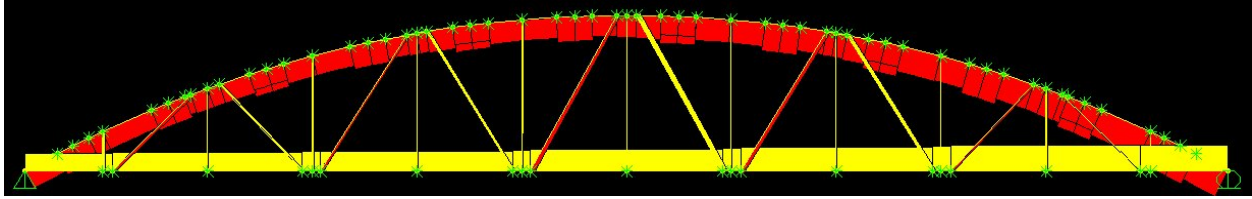

Figure 7. Axial loads under dead load plus unbalanced snow load on right hand side. Webs with red highlight are stressed in compression. Webs reverse sign when unbalanced snow is on the left.

The first Snow Load Analysis for Oregon (SLAO) was not published until 1971. [16] It was adopted by the state of Oregon in 1974 in Oregon's first statewide building code. This document contained ground snow loads for each county in the state based on snow load measurements taken between 1940 and 1969. For the trusses in this paper, this

Currently in Oregon, snow loading is based on the 4<sup>th</sup> edition of Snow Load Analysis for Oregon [18] and the provisions of ASCE7-10, "Minimum Design Loads for Buildings and Other Structures." (ASCE7-10) [19]. The SLAO contains a requirement for a Rain-on-Snow Surcharge and a minimum roof snow load of  $20 \text{ psf} * I_s$ , where  $I_s$  is the snow load importance factor. ASCE7-10 contains the methods for determining drifting snow and unbalanced snow loads. Currently unbalanced snow loads for curved roofs (i.e. bowstring trusses) are derived by applying a linearly varying load equal to half of the roof snow load at the ridge to twice the roof snow load at the eave.

These snow loads can be substantially greater than the roof design load used for the original design. The current unbalanced load condition affects the trusses by causing reversal of stresses and significantly higher loads in the webs and in the web to chord connections.

The trusses considered in this paper may have been designed using balanced snow loads only neglecting drifting and unbalanced loading. After the significant snowfall in December 2016 and January 2017, WWS' engineers inspected twelve buildings in Oregon and Washington with failed trusses. Snow accumulation on one side of the truss was a common cause for these failures.

#### **Partial support of top chord at bearings.**

Except for the TECO truss, the heel assemblies of these trusses use a steel butt plate at the end of the top chord welded to steel side plates that were bolted to the bottom chord. With the TECO truss, wood side plates and a wood block connected the top chord to the bottom chord. These plates and blocks were connected using split rings. To provide the required end distance for the connectors, the top chord was cut horizontally on the soffit leaving a portion of the top chord unsupported at the bearing. See Figure 8. The top chords tend to split at the face of the bearing. This split can propagate up the top chord until at some point the top chord fails. (See photo #3) Often the bottom chord fails at the same time.



The unsupported portion of the top chord at the bearing acts as a beam notched on the tension face at the support. Using current design requirements contained in NDS section 3.4.3.2a, the shear capacity of a notched member is reduced as follows. [20]

$$V_r' = [2/3 * F_v' * b * d_n] [d_n/d]^2$$

For the bearing condition shown in Figure 8,  $d = 12.9''$  and  $d_n = 9.1''$ . The allowable shear capacity in the top chord is roughly 35% of the shear capacity of a fully supported member.

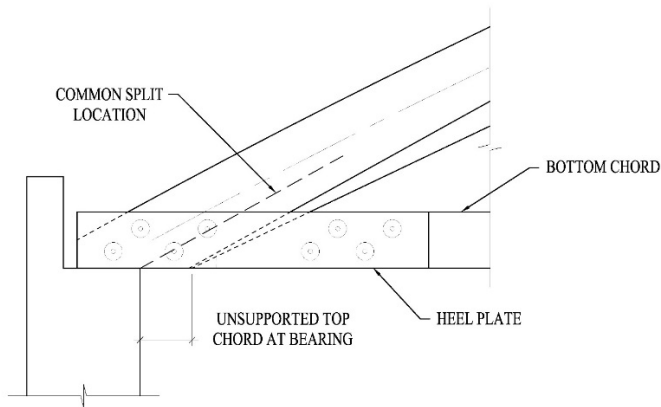

Figure 8. Unsupported top chord at bearing



Photo #3. Top Chord failure at truss heel.

### Row Tear Out at heels and bottom chord splices.

In the 2005 NDS, Appendix E was added which contains recommendations for determining row tear-out and group tear-out capacities for timber connections. Using the at-the-time allowable tension stress for a 3x10 member of 1450 psi and load duration factor,  $C_D = 1.15$ , the allowable tension force in the member based on net area is equal to  $2.5 * (9.25 - 2(1.125)) * 1450 * 1.15 = 29,181.25$  lbs. The capacity for a bolted connection with (2) rows of (4) 1" diameter bolts has a capacity of 30,880 lbs. The row tear-out capacity for this connection with 4" bolt spacing is,

$$Z_{RT}' = nF_v't_{critical} = 2 * 4 * 180 * 1.15 * 2.5 * 4 = 16,560 \text{ lbs.}$$

Clearly, the row tear-out capacity of such a joint is significantly less than the member or bolt capacity. Row tear-out failures are not uncommon. (See photos #4 and #5)



Photo #4. Row tear-out of bottom chord at splice connection.



Photo #5. Group tear-out of truss bottom chord.

### **Decayed Heels/ plugged roof drains**

It is not uncommon to find significant water stains on trusses near the heels. Many buildings with parapets constrain the runoff of water from the roof. When the roof drains plug or the roofing fails, the truss heels are exposed to water. Long term exposure to water will lead to decay and degradation of the truss members. Water intrusion issues can be detected by water staining on the truss members. If decay is suspected, non-destructive inspection techniques such as boring the members with a resistograph can be used to determine the extent of damage.

This type of decay and degradation is also common when trusses are in facilities with high humidity. Food processing plants, paper mills and brick foundries, etc. routinely have high levels of humidity and/or elevated temperatures. The constant exposure to humidity provides an environment conducive to decay fungus.



Photo #6 Decayed heel caused by poor roof drainage Note the water staining on the members.



### **Over-framed roofs.**

Often one or more trusses are positioned end to end and the valley between the trusses is over-framed to form a flat roof. In photo #7 below, the left side of the truss is over-framed to form a flat roof. The roof “beam” is supported by the vertical truss webs that are extended to the roof. When this roof configuration is used, the top chord below the over-framing is unsupported laterally between the vertical webs. The top chords for a full bowstring truss typically have roof joists attached at 2’-0” on center and the L/d ratio for the chord is 9.6. With the over-framing, the L/d ratio increases to 30 with vertical web spacing at 6’-3” on center.  $C_p$  drops from 0.92 for the standard configuration to 0.28 for the over-framed condition. With this reduction in  $C_p$  and allowable load capacity, many top chords become overstressed and need to be stiffened.

This roof configuration significantly changes the way that the loads are applied and resisted by the trusses. For the truss in photo 7, under dead load plus balanced snow load, the moment in the top chord at the first vertical web increases from 11,647.62 psi. on the right side of the truss to 22,256.23 psi on the left side. This increase in bending stress and the decrease in axial load capacity resulted in an increase from 0.6612 to 1.3768 in the interaction formula for combined bending and axial load. The loads in the bottom chord are significantly increased in the overframed area. The roof beam is supported by the vertical web and the axial force in the web is resisted by both the top and bottom chord. This usually results in large moments in the bottom chord. The analysis of these members indicates high shear forces in the vertical webs.



Photo #7. Truss with over-framing on one side.

### **Added Loads**

It is not uncommon for new loads to be added to these trusses. These trusses are most efficient when the loads are applied to the top chord. Often new loads are applied that were not included in the original design. HVAC equipment is often added to the top of the roof or is suspended between the top and bottom chords. With this load application, the trusses usually are able to support the load without becoming overstressed. When equipment or crane rails, basketball standards, etc. are supported from the bottom chord, there is a greater possibility that the bottom chord will be overstressed. It is not uncommon to have a ceiling supported by the bottom chord. This load rarely causes an overstressed condition. There have been several cases where the area above the ceiling is used for storage. In one case an occupied office space was built into the area above the ceiling. The office had standard office furnishings such as desks, file cabinets and assorted items supported by the bottom chord. This added load resulted in failure of the bottom chord in two of the three trusses supporting the office.

### **Damage from vehicle collisions and other loads.**

It is also not uncommon to be called to a facility where a truss is damaged by a forklift traveling under the trusses with the mast extended. It does not take a significant impact to break the bottom chords. Other unanticipated loads include basketball standards supported from the bottom chords and chain hoists supported from the bottom chord.

### **Load Duration effects**

The load duration factor used in the United States is based on work done by L. W. Wood in the late 1940s and into the 1950s. [21]. This work resulted in the plot of duration of load vs. stress level known as the Madison Curve. The work completed by Wood yielded an equation for load duration factor as shown in equation (1)

$$SL = 108.4/(D^{0.04635}) + 18.3 \quad \text{Equation (1)}$$

With D in hours.

Subsequent work by Charles C. Gerhards in 1977 resulted the following expression;

$$SL = 87.8 - 4.8 \log_{10}D \quad \text{Equation (2)}$$

Also with D in hours

It is instructive to compare the load duration factor obtained from equations (1) and (2) with the current load duration factor for permanent loading. For a truss built in 1945,  $D = 74 \times 365 \times 24 = 648,240$  hours and the resulting Load Duration Factors become 0.766 and 0.599 for equation (1) and (2) respectively. Both values are significantly less than 0.9. Subsequent studies in Canada conclude that “the Madison curve is unduly conservative up to about 2 years and after that it is unsafe.” [22]. When analyzing these trusses, the reduced duration of load factor should be considered.

### Example using Gerhard's duration of load factor

In 2012, a TECO bowstring roof truss in the gymnasium of Pilot Rock High School in Pilot Rock, Oregon failed. At the time of the failure there was no snow or roof live load present. The trusses were 100'-0" long and spaced at 18'-8" on center. The bottom chords were double 3x10 members with (2) 4" diameter shear plates at the bottom chord splice. The tension force for **dead load only** load combination is 14,450 lbs. and the bending moment is 10,023 in.-lbs. for each bottom chord leaf. The net area for one bottom chord leaf is 17.96 in<sup>2</sup>. The bottom chord material was specified as conforming to paragraph 204 of WCLA rules #14, equivalent to current Douglas fir #1. However, the splice is located outside of middle 1/3 of the member where the grading rules allow larger knots and steeper slope of grain. The Demand to capacity ratio using Douglas fir #2 and a load duration factor,  $C_D = 0.6$  is:

$$f_t = T/A = 14,450/17.96 = 804.57 \text{ psi.}$$

$$f_b = M/S = 10,023/37.6 = 266.5 \text{ psi.}$$

$$F_t' = F_t * C_F * C_D = 575 * 1.1 * 0.6 = 379.5 \text{ psi}$$

$$F_b' = F_b * C_F * C_D = 900 * 1.1 * 0.6 = 594.0 \text{ psi}$$

$$f_t/F_t' + f_b/F_b' = 804.57/379.5 + 266.5/594.0 = 2.12 + 0.45 = 2.57$$

The average factor of safety for wood members is 2.85 and the lower 5% tolerance limit factor of safety is 2.1. The combined demand to capacity ratio for this example **for dead load only** is 2.57, which clearly falls within this range and could certainly result in failure of the bottom chord.

The reduction in duration of load will also affect the other strength related issues previously discussed such as the shear capacity of the unsupported bearing condition at the top chord of TECO trusses and the row tear-out capacity of bolts at the bottom chord splices.

### Upgrade/Repair vs. roof replacement

In every case where the owner has compared a roof replacement with a repair and upgrade procedure, the repair and upgrade choice has been significantly less expensive and far less disruptive to the tenant. A roof replacement requires a total evacuation of the space and will often trigger a code upgrade for other portions of the building including seismic upgrades, accessibility and egress. Most Jurisdictions Having Authority will allow a permit for the repair and upgrade of the trusses without adding other upgrade conditions.

As a recent example, a building in north Portland had a fire that damaged three bowstring trusses plus four bays of roof framing (80'x60'). The rebuild required a seismic upgrade in the fire damaged area. The rebuild, including three new trusses, four bays of framing and sheathing and all seismic attachments cost \$172,164.00. The rebuild required additional costs for demolition, new roofing, lights and HVAC equipment.

The same building had another bowstring truss that was damaged by a forklift which broke the bottom chord. The cost to repair and upgrade this truss to meet current load conditions was \$27,834.00. The total cost to repair three trusses would be \$78,702.00. This example clearly demonstrates that upgrading trusses is significantly less expensive than replacing the trusses and the roof on the adjacent bays.



## Repair and Upgrade Procedures

To properly repair and/or upgrade a truss, every non-code-conforming issue must be addressed. Repairing a broken bottom chord with a new splice does not reduce the stresses in the members. Often the chord will break just beyond the repaired section. The following suggestions and methods have been shown to successfully upgrade and repair these trusses.

1. Begin with an onsite inspection

An inspection will uncover distressed conditions, decay and damage due to such things as collisions with equipment. (forklifts, etc.) Often the trusses have been modified by previous repairs, removal of webs, or by adding additional loads to the truss. HVAC units are often installed on the roof, suspended from the top chord or supported on the bottom chord. When ceilings are attached to the bottom chord, this area often becomes a storage area and in extreme cases, an occupied room.

During the inspection, be on the lookout for failures that are common to several trusses. When a failure repeats itself in the same place on several trusses, it can be concluded that there is a design issue to be addressed. Failures due to overloading are usually isolated and occur at a lower strength member which are randomly placed in building.

2. Analyze the trusses using current loading requirements and analysis methods.

The loads used in the analysis should include the current code required snow loads, both balanced and unbalanced, and actual loads found supported by the trusses.

The analysis model should accurately represent the member continuity, the non-prismatic section properties, if present, the eccentric web-to-chord connections, and the member fixity at connections. Computer analysis will accurately yield the location and magnitude of member forces and will capture the moments due to member continuity and secondary stresses due to deformations.

A design check should be completed for each member and each connection using current timber design methods, including row tear-out and group tear-out at members carrying tension forces. Currently row tear-out and group tear-out are included in the NDS appendix E as non-mandatory provisions. However, the common occurrence of these failures is best addressed by these provisions. Current allowable timber stresses and connection capacities should be used in the design check

3. Post-tensioning of the bottom chord vs adding steel plates or channels:

WWS prefers using a post-tensioning system on the bottom chords of these trusses as opposed to adding steel plates or channels. Since it is not uncommon for the bottom chord to be overstressed in the dead load only load combination, a method that actively reduces the tension in the bottom chord is preferred. There are several downsides to using steel plates and channels. While these elements add strength to the member, they do not reduce the stress in the members and add a significant amount of weight to the already overstressed members. These added members do not engage and begin to carry load until the connections attaching the steel members to the wood members fully set. With a 1/16" oversized hole, the wood member needs to elongate 1/32" before the steel member

engages. For a 20-foot 3x8 chord, it takes 3,776 lbs. to cause 1/32" elongation. Only after the wood member takes the 3,776 lbs. of load, the remaining loads are added to the chord and the steel member in relation to the relative stiffness of each member. Taking all this into account, the steel member may not reduce the stresses in the wood or increase the capacity of the member to the point where the chords are no longer overstressed.

A properly designed post-tensioning system will include a method of verifying the actual post-tensioning force induced into the cable. This can be accomplished by using calibrated hydraulic jacks and by measuring the elongation of the cable during post-tensioning procedures. When post tensioning is applied, the gauge pressure does not increase until all the joints in the bottom chord set. Basically, the bottom chords are contracted by the force in the cables until all the connectors are completely set. The post-tensioning force read from the gauge is equal to the tension force induced into the cable and the compressive force induced into the bottom chord.

4. Replacing the bottom chord with glued-laminated members.

When the bottom chord is overstressed in bending moment, it can be difficult to attach a member that increasing the bending capacity. In these cases, the bottom chords may need to be replaced by high grade glued-laminated members. Glued-laminated timber can be purchased with a tensile stress of 1650 psi. This higher strength material is often adequate to provide the required capacity. The bottom chords for the Summerbell, TECO and the McKeown Lattice Trusses can be replaced with wider members since they are located on either side of the webs.

5. Attaching side members to the top chord

When the top chords are overstressed, they can be replaced with higher strength glued-laminated members or they can have members "sistered" on to the face of the member. The design of these added members must account for the shored or unshored condition of the truss at the time the side members are added. If the trusses have not been jacked up to the original unloaded condition, the existing members will carry all the forces due to the dead loads and the transformed section will carry the snow or roof live loads. If the trusses are jacked up to their original position, then the transformed section will carry all the loading.

6. Attaching side members to webs

When the webs are overstressed in compression, the strength of the web can be increased by decreasing the L/d ratio of the web. This is accomplished by adding a member to one or more sides of the web. Adding members to the sides of the web increases the stiffness thereby increasing the column stability factor  $C_p$  and increasing the allowable compressive stress. The original web area is checked for compression using the new allowable stress. The area of the new side members is not included when calculating the applied axial stress, since the web is currently carrying the compression due to dead loads and there is no connection between the new web members and the chords.

7. Addressing overstressed connections

When the connections of the web to the chords are overstressed, additional connectors will need to be added. Since the code does not allow mixing of connectors, an upgrade design must use the same connectors as the original design. (for example, bolts cannot be added to a connection made with split rings.) When new timber connectors, such as split rings or shear plates, are added, any reduction of the chord section will need to be considered.

**Conclusion**

During the time from the late 1920s to the mid-1960s, bowstring trusses were installed in thousands of buildings nationwide. These trusses predominately used one of four configurations referred to as McKeown Lattice Trusses, Summerbell Trusses, TECO Trusses and Tim Trusses.

The design of these trusses, while conforming to the code requirements of the time, do not meet current code requirements. The following issues were addressed.

1. Snow loads, balanced or unbalanced may not have been considered in the design of these trusses.
2. The original designs used allowable tension values that subsequently have been shown to be significantly nonconservative.
3. The analysis methods used in the original designs were not capable of accounting for the forces induced into the members from continuity at the joints, eccentric web to chord connections and secondary forces caused by deflections.
4. Since the time when these trusses were designed and installed, there have been several provisions added to the timber design codes, such as notched shear strength which affects the strength of the bearing condition of TECO Trusses and row tear-out strength and group tear-out strength at connections which affects the strength of bolted connections in tension.
5. The load duration factor in the current code is unconservative for members that are overstressed in the dead load only load combination. These members have been supporting the dead load for 60 to 90 years.

These issues collectively explain why these trusses will often fail when no applied live loads are present on the roof.

The most common areas to look for truss failures or overstressed conditions are:

1. Split top chords at the heel connection
2. The top and bottom chords at the first vertical web location.
3. The bottom chord at the heel assembly or bottom chord splice.
4. Decayed top and bottom chords at the heels when a parapet is present.

These trusses can be repaired and upgraded to meet current requirements using current allowable timber stresses. These repairs and upgrades are significantly less expensive than removing and replacing the trusses.

## References

- [1] Gilham, Paul C., McKee Terry D. "Bowstring Trusses "Fail to Meet Current Code Requirements", 1990 Published in the newsletter of the Structural Engineers of Oregon.
- [2] Timber Engineering Company. "Typical Designs of Timber Structures". Washington, D. C. 1941.
- [3] U. S. Forest Service Research Note FPL-0158. March 1967. "Casein Glues: Their Manufacture, Preparation, and Application."
- [4] Eschenasy, D., P.E., F.SEI, SECB. STRUCTURE Magazine December 2018. Chicago, IL.
- [5] McKeown Brothers Co., Drawings archived at NY Department of Buildings, 1924
- [6] International Conference of Building Officials. "Uniform Building Code, 1967 Edition." Pasadena, CA.
- [7] American Institute of Timber Construction. "AITC Technical Note 26, Design Values for Structural Glued Laminated Timber in Existing Structures" April 2007. Centennial, CO
- [8] American Wood Council. "National Design Specification for Wood Construction, 2012 Supplement", table 4A. Leesburg, VA
- [9] West Coast Bureau of Lumber Grades and Inspection. "Grading and Dressing Rules #14". 1947. Portland, OR
- [10] West Coast Lumber Inspection Bureau. "Standard #17 Grading Rules for West Coast Lumber". 2004. Portland, OR
- [11] Ebling, Dick W. "Repair and Rehabilitation of Heavy Timber Trusses." Presented at the May 2, 1990, Structures Conference in Baltimore, MD.
- [12] American Wood Council. "ANSI/AWC NDS-2012, National Design Standard for Wood Construction." Leesburg, VA
- [13] Pacific Coast Building Officials Conference. "Uniform Building Code, 1927 Edition." Los Angeles, CA.
- [14] Pacific Coast Building Officials Conference. "Uniform Building Code, 1940 Edition." Los Angeles, CA.
- [15] Pacific Coast Building Officials Conference. "Uniform Building Code, 1949 Edition." Los Angeles, CA.
- [16] Structural Engineers Association of Oregon. 1971, "Snow Load Analysis for Oregon" Portland, OR
- [17] NBC of Canada, 1970 Supplement No. 4, Commentary No. 2, "Snow Loads".
- [18] Structural Engineers Association of Oregon. 2013, "Snow Load Analysis for Oregon, Fourth Edition." Portland, OR
- [19] American Society of Civil Engineers, 2010, "ANSI/ASCE7-10, Minimum Design Loads for Buildings and Other Structures" Reston, VA
- [20] American Wood Council. "National Design Specification for Wood Construction, 2012, Section 3.4.3.2a, Leesburg, VA
- [21] Gerhards, Charles, C. "Effect of Duration and Rate of Loading on Strength of wood and wood-Based Materials." 1977. US Forest Service Research Paper FPL283. Madison, WI.
- [22] Madsen, Borg. "Structural Behavior of Timber." 1992. Timber Engineering Ltd. Vancouver, BC.